

X-SECTION OF OLD N . H-24 (CITY PORTION)
(SCALE 1:200)

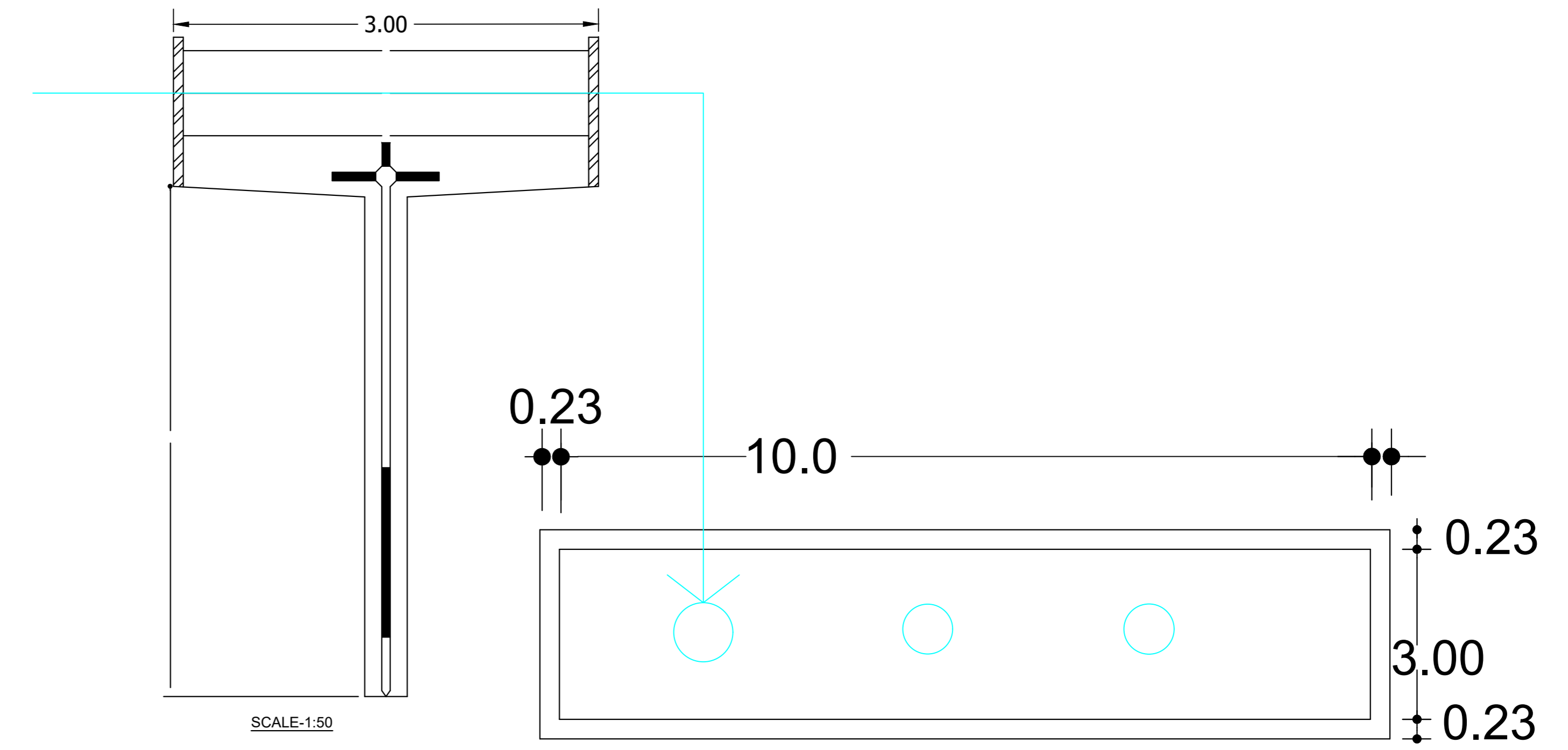

SEC.R.C. SHAFT
PLAN LATERAL RECHARGE TANK
DETAIL OF RAIN WATER HARVESTING SYSTEM

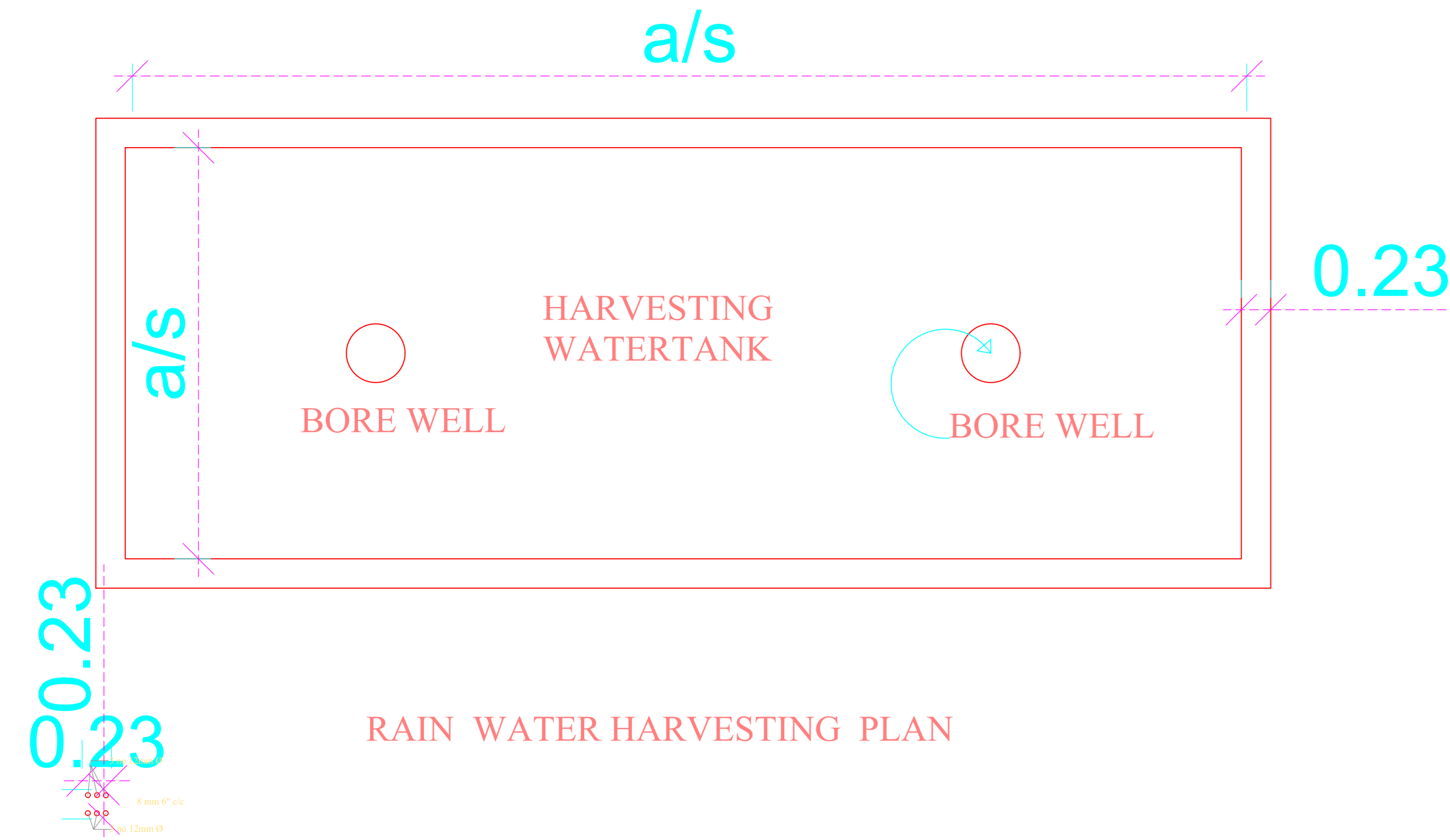

RAIN WATER HARVESTING PLAN

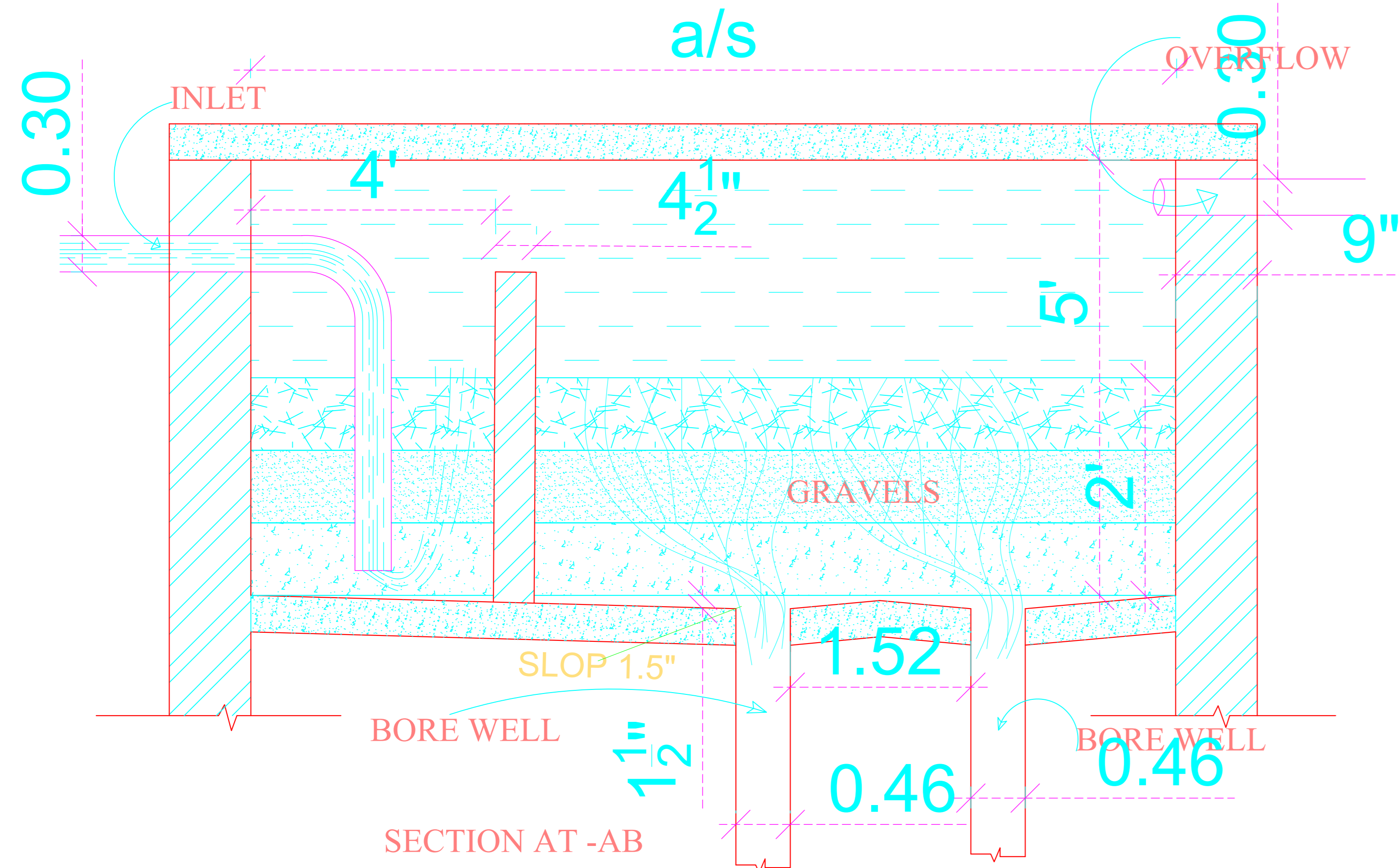

SECTION AT -AB

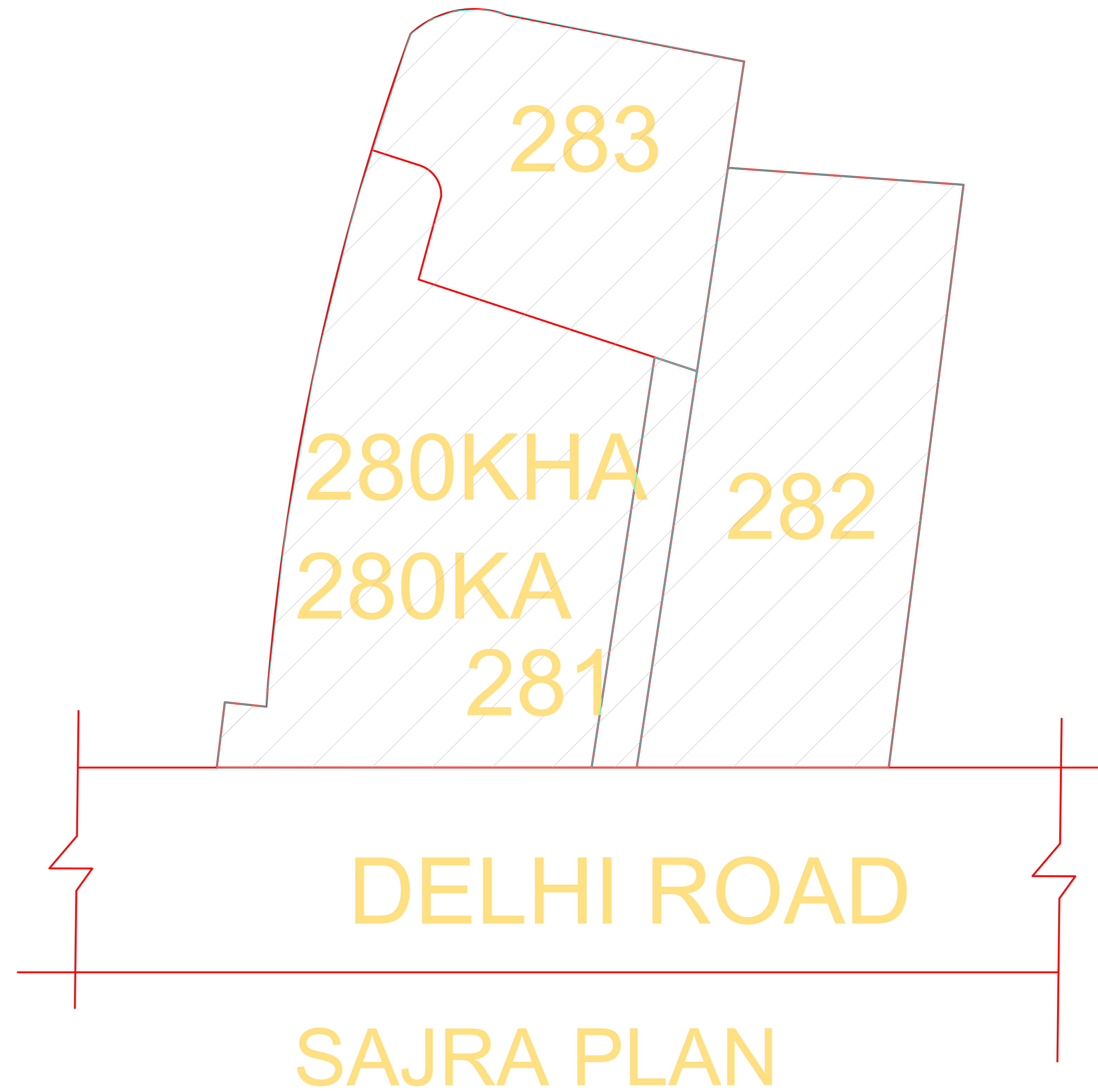

OWNER'S NAME AND SIGNATURE
AYDHESH KUMAR
ETC. ABBASFAISAL1993@GMAIL.COM.9528030567

ARCHENG'S NAME AND SIGNATURE
STRUCTURE ENGINEER

PARAG AGARWAL
CA/9823068
State: Uttar Pradesh
Date: 22 Nov 2022
Designation: Member
Development Authority

Moradabad Development Authority



Building Plan Application Number

MBD/ALD/21-22/0392

Sanctioned On

22 Nov 2022

Valid Till

23 Nov 2027

Approved By

Shailesh Kumar (Vice Chairman)

Examined By

RAJENDRA PRASAD YADAV (Junior engineer)

sagar gupta (Assistant Engineer/ ATP)

Kaushvendra Kumar Gautam (Town Planner)

Kaushvendra Kumar Gautam (Chief Town Planner)

Rajeev Pandey (Secretary)

Shailesh Kumar (Vice Chairman)

Note: - 1) This drawing is prepared as per the current prevailing Building Bye Laws.
2) If Map sanctioned is used for purpose anything other than stated in application will lead to rejection of Map.

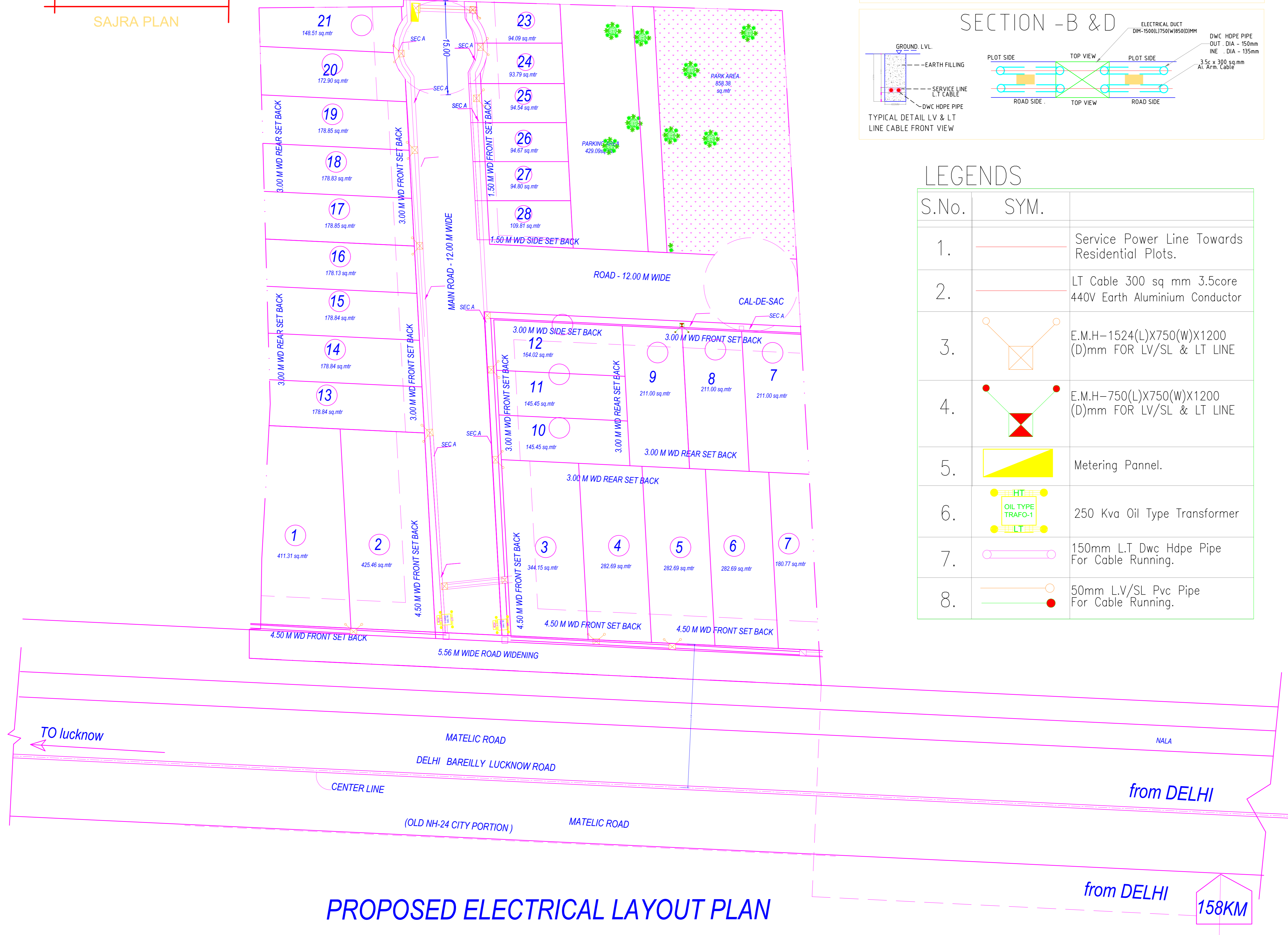
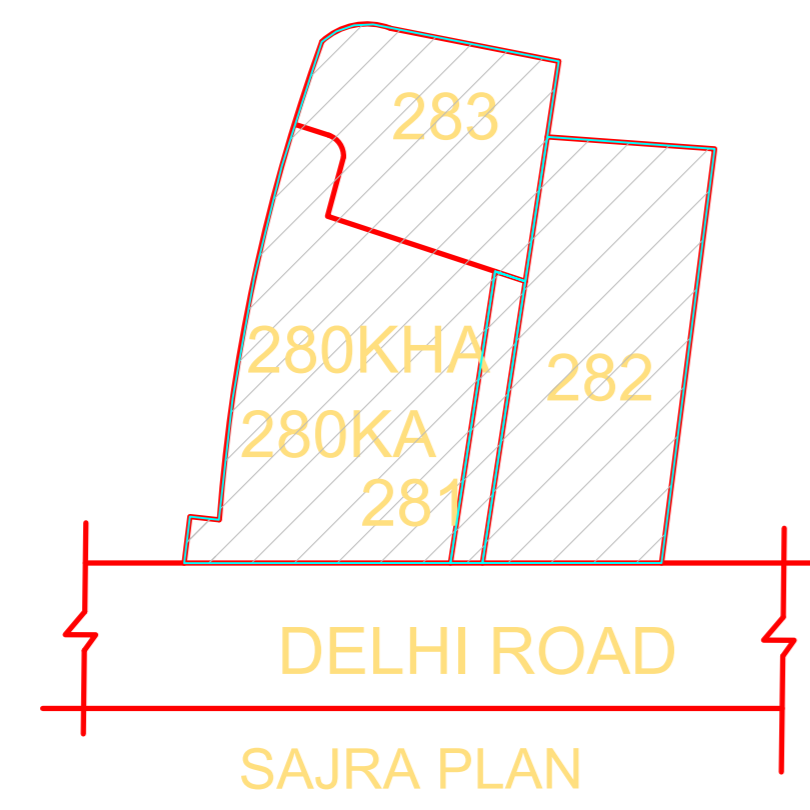

LEGENDS

S.No.	SYM.	Description
1.		Service Power Line Towards Residential Plots.
2.		LT Cable 300 sq mm 3.5core 440V Earth Aluminium Conductor
3.		E.M.H-1524(L)X750(W)X1200 (D)mm FOR LV/SL & LT LINE
4.		E.M.H-750(L)X750(W)X1200 (D)mm FOR LV/SL & LT LINE
5.		Metering Pannel.
6.		250 Kva Oil Type Transformer
7.		150mm L.T Dwc Hdpe Pipe For Cable Running.
8.		50mm L.V/SL Pvc Pipe For Cable Running.

Note: - 1) This drawing is prepared as per the current prevailing Building Bye Laws.
2) If Map sanctioned is used for purpose anything other than stated in application will lead to rejection of Map.

Total Plot Area: -	8581.70	Total FAR Area: -	0.00
Total Coverage Area: -	0.00	Total BUA Area: -	0.00

OWNER'S NAME AND SIGNATURE
AVDRESH KUMAR
ETC. ABBASFAISAL1993@GMAIL.COM.9528030567

ARCHENGE'S NAME AND SIGNATURE
STRUCTURE ENGINEER
PARAG AGARWAL
CA/9823068
Date: 22 Nov 2022
Time: 11:30 AM
City: Moradabad
MORADABAD DEVELOPMENT AUTHORITY

Building Plan Application Number
MBDA/LD21-220392
Sanctioned On
22 Nov 2022
Valid Till
23 Nov 2027
Approved By
Shailesh Kumar (Vice Chairman)
Examined By
RAJENDRA PRASAD YADAV (Junior engineer)
sagar gupta (Assistant Engineer/ ATP)
Kaushendra Kumar Gautam (Town Planner)
Kaushendra Kumar Gautam (Chief Town Planner)
Rajeev Pandey (Secretary)
Shailesh Kumar (Vice Chairman)