

24.0 M WIDE ROAD
100.780

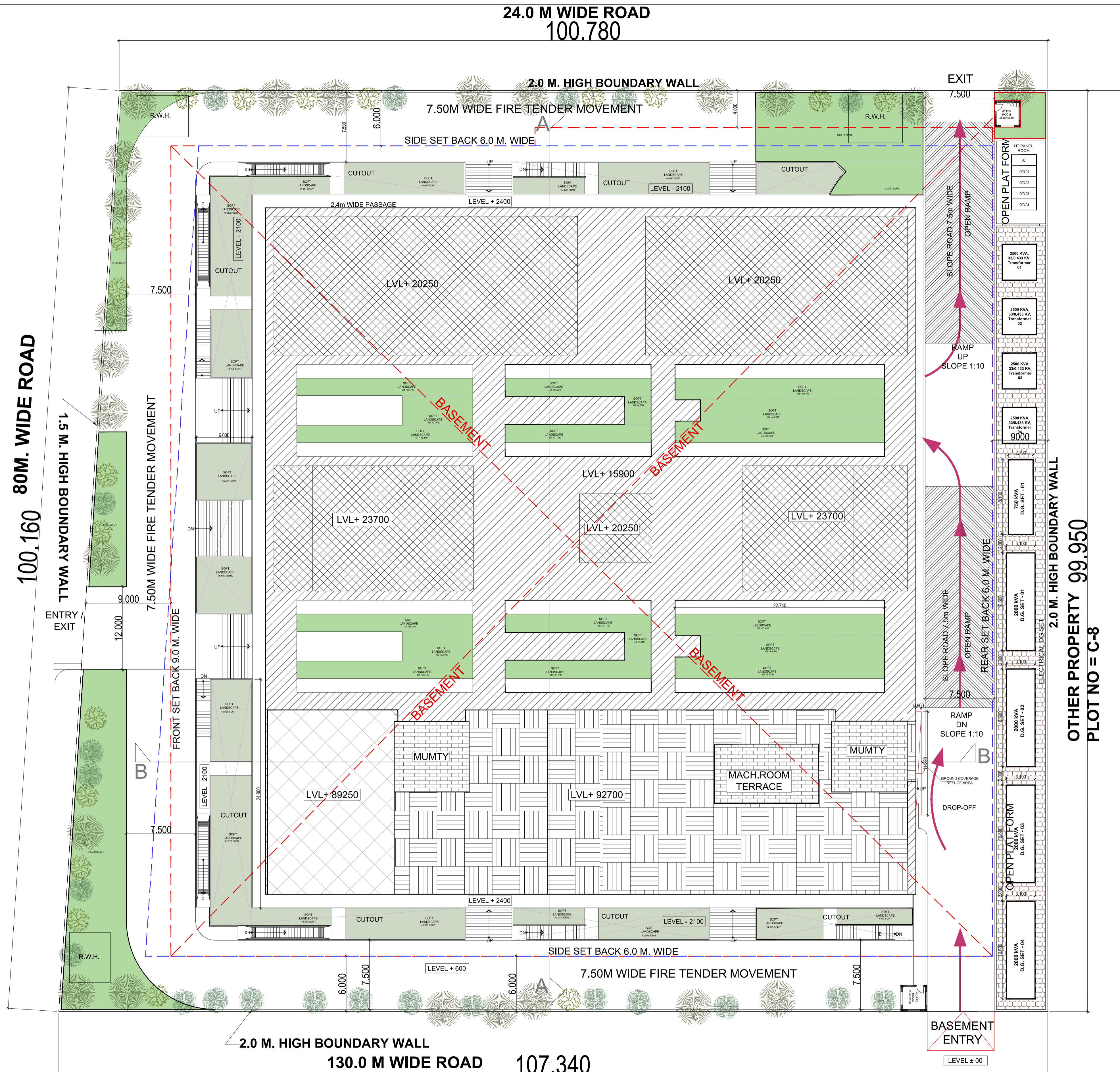

GUARD & METER ROOM AREA DETAIL

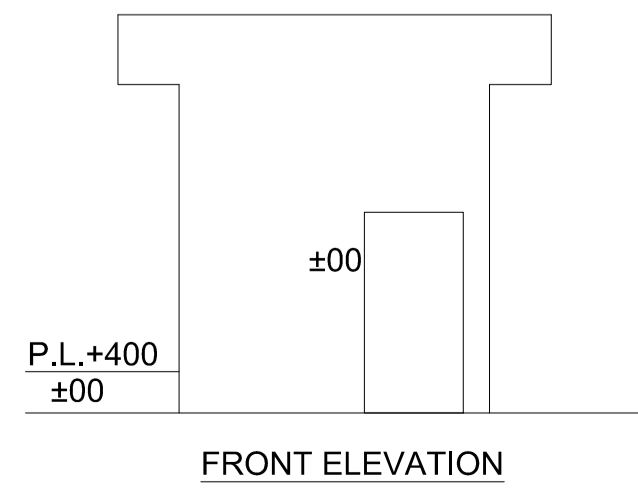
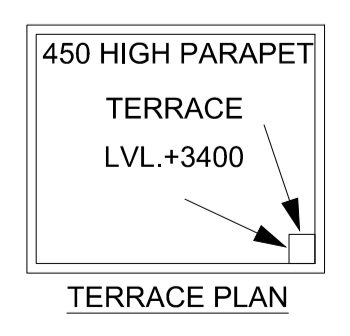
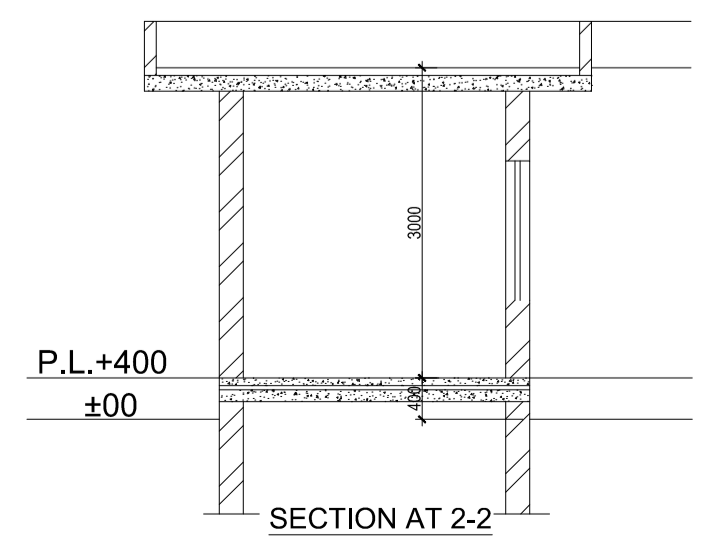
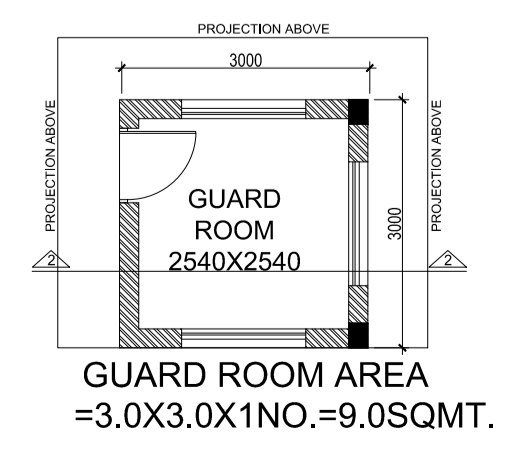
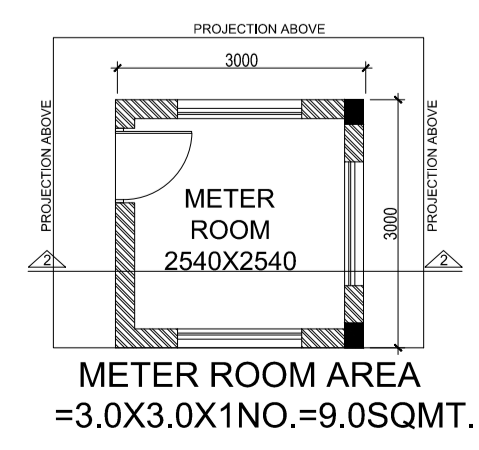

OWNER'S SIGN.	
ARCHITECTS SIGN RAJIV GANDHI ARCHITECT LIC.NO.- CA/91/13852	
STRUCTURAL CONSULTANT	
PROJECT PROPOSED PLAN FOR NIRALA GATEWAY C-7,SECTOR - 12 GREATER NOIDA WEST FOR M/S.PARTH BULTECH PVT.LTD	
DRAWING TITLE WASTE DISPOSAL PLAN	
Scale	1:200
Date	
SHEET. NO.	DRG. NO.
JOB. NO.	01

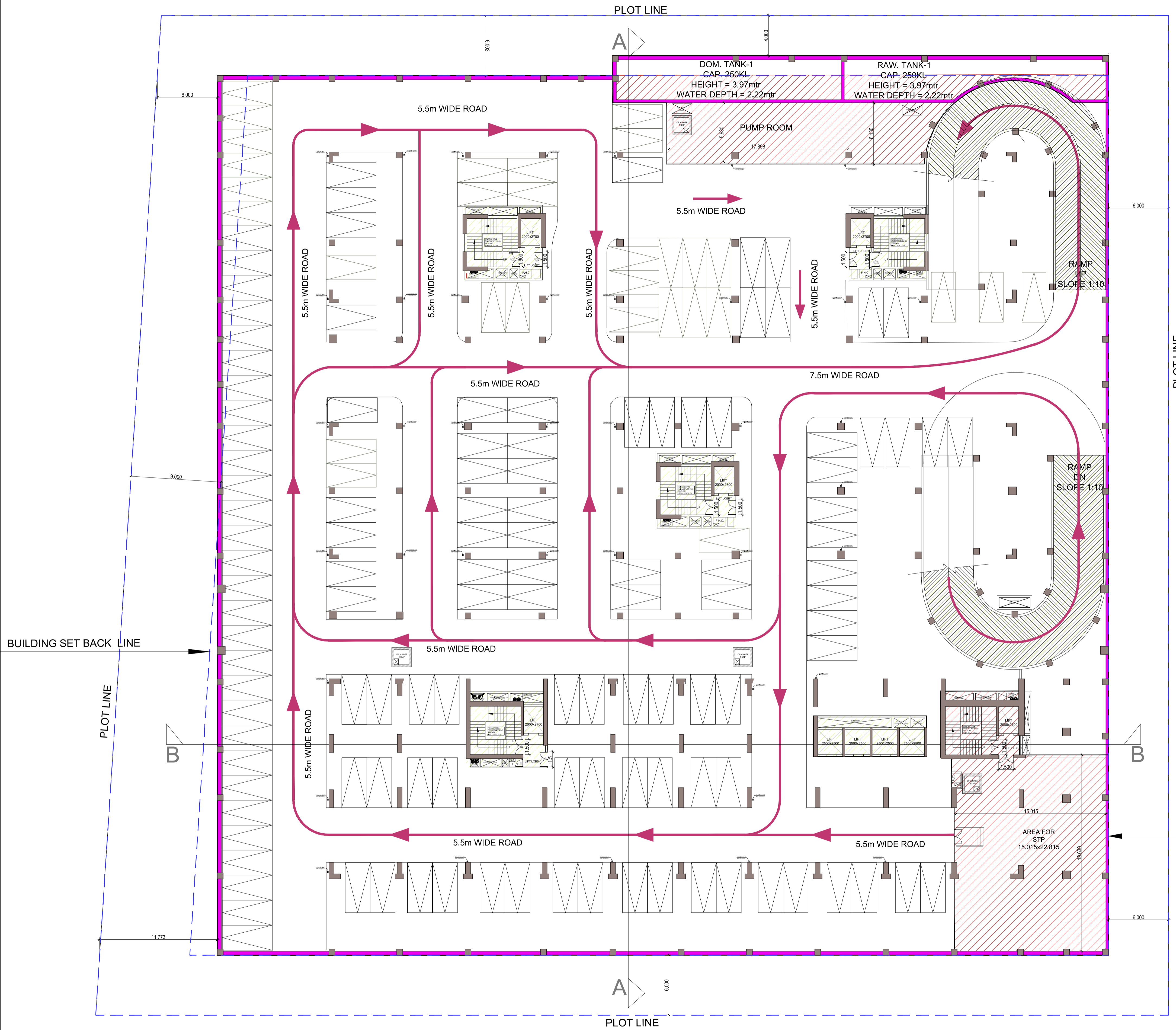

2ND. BASEMENT PLAN

SUBMISSION DRAWING

OWNER'S SIGN.	
ARCHITECTS SIGN RAJIV GANDHI ARCHITECT LIC.NO.- CA/91/13852	
STRUCTURAL CONSULTANT	
PROJECT PROPOSED PLAN FOR NIRALA GATEWAY C-7, SECTOR - 12 GREATER NOIDA WEST FOR M/S.PARTH BUILTECH PVT.LTD	
DRAWING TITLE WASTE DISPOSAL PLAN	
Scale	1:200
Date	
SHEET. NO.	DRG. NO.
JOB. NO	

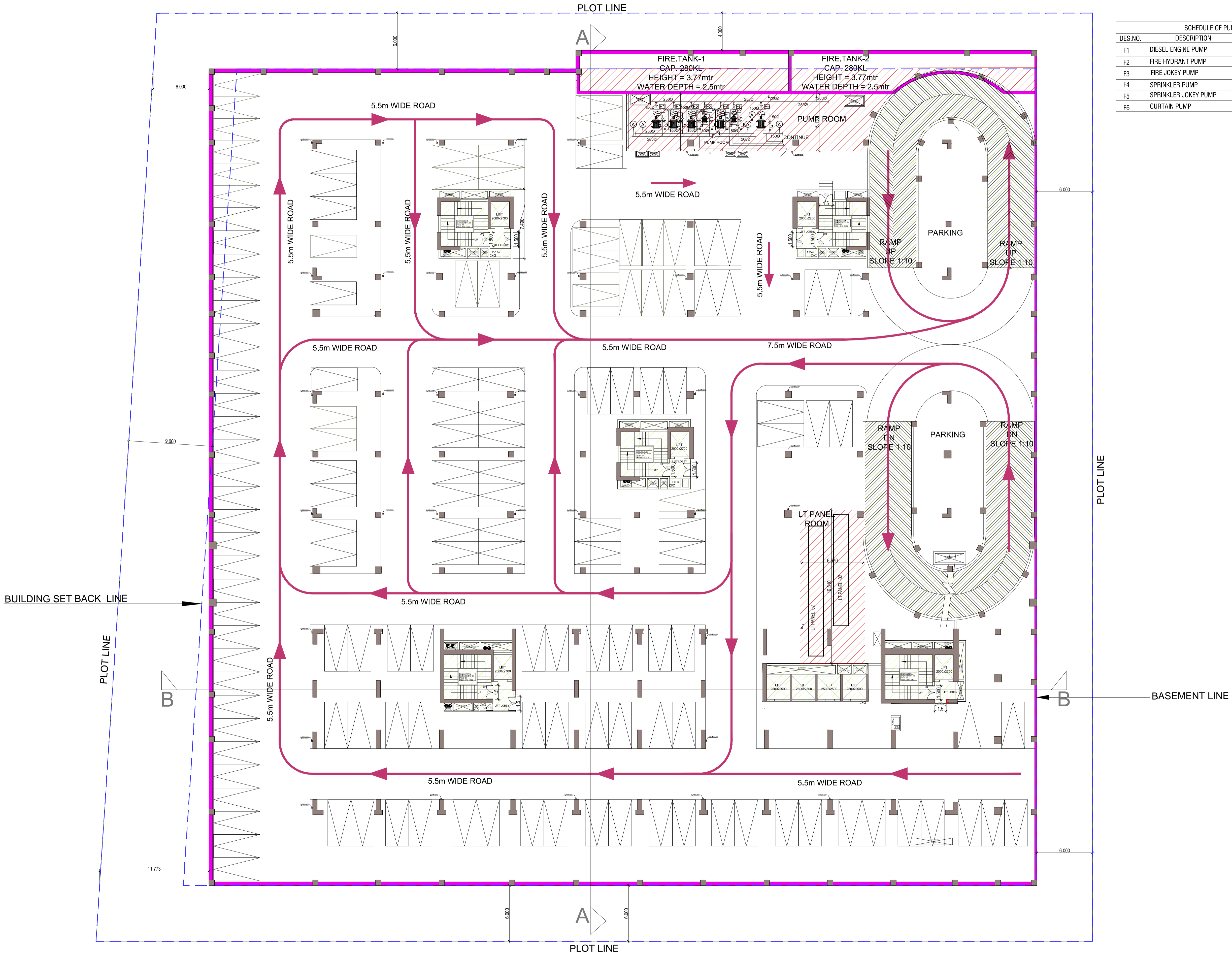

SCHEDULE OF PUMPS AND EQUIPMENTS			
DES.NO.	DESCRIPTION	CAPICITY	NO. OF PUMP
F1	DIESEL ENGINE PUMP	2850 lpm@185MT head	2. NO.
F2	FIRE HYDRANT PUMP	2850 lpm@185MT head	1. NO.
F3	FIRE JOKEY PUMP	180 lpm@185MT head	1. NO.
F4	SPRINKLER PUMP	2850 lpm@185MT head	1. NO.
F5	SPRINKLER JOKEY PUMP	180 lpm@185MT head	1. NO.
F6	CURTAIN PUMP	2280 lpm@60MT head	1. NO.

1ST. BASEMENT PLAN

SUBMISSION DRAWING

OWNER'S SIGN.	
ARCHITECTS SIGN RAJIV GANDHI ARCHITECT LIC.NO.- CA/91/13852	
STRUCTURAL CONSULTANT	
PROJECT PROPOSED PLAN FOR NIRALA GATEWAY C-7,SECTOR - 12 GREATER NOIDA WEST FOR M/S.PARTH BUILTECH PVT.LTD	
DRAWING TITLE WASTE DISPOSAL PLAN	
Scale	1:200
Date	
SHEET. NO.	DRG. NO.
JOB. NO	